

TIC-ESTS

The Security Settlement System of the Central Bank of the Republic of Turkey

Response to the Disclosure Framework for Securities Settlement Systems

October 2001

This responses contained herein reflect, to the best of the knowledge of respondent, The Central Bank of the Republic of Turkey (CBT), accurate information. However, neither CBT nor any related entity, either collectively or separately, warrant the accuracy or completeness of the information contained in the CBT's response to questionnaire. In no event will CBT or any related entity, either collectively or separately, be liable to any party for: (1) any decision made or action taken by the particular party in reliance upon the information contained in this questionnaire, (2) any losses or damages, regardless of how caused, including, but not limited to, loss of business revenue or profits or any direct, indirect, special, incidental or consequential damages arising out of the use of this questionnaire.

Table of Contents

I. Basic Information.....	3
II. Rules and procedures of the SSS.....	8
III. Relationships with participants	10
IV. Relationships with other SSSs and commercial intermediaries	13
V. Securities transfers, funds transfers and linkages between transfers	16
VI. Default procedures	23
VII. Securities overdrafts, securities lending and back-to-back transactions	26
VIII. Risk control measures	29
IX. Operational risks	35

List of Figures

Figure–1: TIC-ESTS and Takasbank SSS.....	13
Figure–2: A Typical DVP Flow in TIC-ESTS.....	16
Figure–3: A Typical Partial DVP Flow in TIC-ESTS.....	20
Figure–4: The Settlement System of the CBT	36

I. Basic Information

A. What is the name of the SSS?

TIC-ESTS (Turkish Interbank Clearing – Electronic Security Settlement System)

B. Where and in which time zone is the SSS located?

TIC-ESTS is located in Ankara-Turkey and in GMT+2 time zone.

C. What functions does the SSS perform?

TIC-ESTS provides issuance, principal and interest payment processing, custody and transfer and settlement services for securities of the Treasury.

1. Does the SSS serve as a securities depository and/or provide securities settlement services?

Both.

(a) What types of instruments are eligible for deposit at the SSS (e.g. debt, equities, warrants, etc.)?

The securities eligible for deposit in the Central Bank of the Republic of Turkey (CBT) are also eligible in TIC-ESTS system. They are G-bonds and T-bills in general. There are also debt instruments issued by some government organizations. Eligible securities may also be denominated to foreign currencies other than Turkish Lira (TL).

(b) What types of instruments are eligible for transfer within the SSS?

All the securities that are eligible for deposit at the TIC-ESTS (Please see I.C.1.a) are also eligible for transfer.

(c) Please describe whether eligible securities are dematerialised, immobilised or transferred physically.

During the issuance of T-bills and G-bonds, only the 5% of securities that are owned by TIC-ESTS participants are printed in a stock in order to cover future physical delivery requests. The remaining 95% is not printed and exists only in the accounts of TIC-ESTS (dematerialised).

Most of the printed certificates are immobilised in the CBT branches at the moment. Transfers of immobilised securities are realized in book-entry form among the accounts within the TIC-ESTS.

It is possible to take securities out of the system and deliver to the owners in physical form, or to immobilise physical securities in TIC-ESTS by taking delivery of physically printed securities in the CBT branches.

(d) Does the SSS provide safekeeping for physical certificates?

The printed certificates, which are stored and transferred within the TIC-ESTS, are immobilised in the CBT branches. TIC-ESTS keeps the securities on the name of its direct participants.

2. Does the SSS provide cash accounts and/or provide funds transfers in conjunction with securities transfers? If so, in what currencies?

TIC-ESTS has integrated with TIC-RTGS (real-time gross settlement payment system of the CBT). The connection between TIC-ESTS and TIC-RTGS allows simultaneous DVP in model 1 (During a DVP transaction while the securities are transferred between the accounts TIC-ESTS, the associated funds are transferred in the accounts in TIC-RTGS simultaneously). They are Turkish Lira based. The Figure-2 shows the details of interaction between TIC-ESTS and TIC-RTGS in a DVP transaction.

A free transfer (a security transfer against no payment) is also possible. Free transfers are rather used as a part of Istanbul Stock Exchange (ISE) settlements that are done through Takasbank (Clearing and custody bank of ISE).

3. Does the SSS provide a trade matching service? Do others provide such services for securities settled at the SSS?

TIC-ESTS does not provide trade matching services to its participants. Istanbul Stock Exchange (ISE), however, does provide trade matching services for TIC-ESTS eligible securities. The final settlement of trades performed on ISE is realized through TIC-ESTS in addition to ordinary participant transactions.

4. Does the SSS provide a trade netting service (as distinct from undertaking the settlement of securities transfers on a net basis)? Do others provide such services for securities settled at the SSS? In either case, what types of netting (bilateral or multilateral), if any, are performed?

TIC-ESTS does not provide a trade netting service. But Takasbank (Clearing and custody bank of ISE) provides multilateral netting service for the trades performed on ISE for securities immobilised or dematerialised in TIC-ESTS.

5. Does the SSS offer a securities lending or borrowing programme?

No, TIC-ESTS does not offer any securities lending or borrowing programme.

It, however, allows repo (repurchase agreements) and repo-return transactions between participants. Participants can use these transaction types for repo and repo-return operations, but trades are not

within the scope of TIC-ESTS. The CBT, as a tool in its monetary policy, performs daily repo/repo-return auctions and settlements as result of auctions are performed in TIC-ESTS on the same day.

At the same time, participants may use repo facilities provided by ISE.

6. Does the SSS provide custodial and/or related services such as the collection of interest, dividends, principal or withholding tax reclamations? Which types of service are provided?

As a fiscal agent of the Treasury that issues securities on TIC-ESTS, the CBT make payments associated with the principal and interest on G-bonds and T-bills.

The CBT makes payments of principal and interest to participants' funds in TIC-RTGS on the due date (or the next business day, if the payment date falls on a weekend or holiday) from available funds of the Treasury (The CBT does not advance funds or securities to or on behalf of other institutions), unless otherwise instructed by the Treasury.

7. Does the SSS act as a central counterparty or principal to transactions with its participants?

The CBT does not act as a central counterparty to any transaction between participants. However, it may be a party to a transaction over the system (for example, during the open market operations).

8. Other? Please specify.

None.

D. What type of organisation is the SSS?

TIC-ESTS is owned, operated and overseen by the CBT.

1. Please indicate whether the SSS is a public sector or private sector entity.

TIC-ESTS is owned, operated and overseen by the CBT.

2. Please indicate whether the SSS is organised on a for-profit or a non-profit basis.

Non-profit basis.

3. What is the legal basis for the establishment of the SSS and for securities transfers made through it?

Under the CBT Law, the CBT is responsible for establishment and oversight of the payment and security settlement systems.

E. Please describe and provide a diagram outlining the organisational and ownership structure of the SSS.

1. Who are the owners of the SSS?

TIC-ESTS is owned by the CBT.

2. What entity or entities operate the SSS? Which functions of the SSS, if any, are outsourced to third parties?

The CBT operates the TIC-ESTS.

3. Does the SSS have a Board of Directors?

Under the CBT Law, The Board of the CBT is authorised to take decisions for the establishment of payment, securities transfer and settlement systems on conditions that shall promote their soundness and effectiveness, to determine the procedures and conditions of payment methods and instruments. The Board is the ultimate decision body about the TIC-ESTS System.

In order to co-ordinate the payment and settlement system activities, the CBT has a special committee working on settlement systems, the HITI committee, which is composed of a directors of 7 related CBT departments and 2 major CBT branches and chaired by a vice governor. This committee takes policy decisions about the system and presents its decisions that affect the rules of the system to the Board for approval.

(a) What is its composition?

The CBT departments represented in the HITI committee are (i), Accounting, (ii) Auditing, (iii) Banking, (iv) Data Processing, (v) Emission, (vi) Law, (vii) Money Market, (viii) Ankara Branch and (ix) Istanbul Branch.

(b) What are its responsibilities?

The HITI Committee is responsible for making policy decisions in order to provide the smooth functioning of the payment and securities settlement systems.

F. Please describe the financial resources of the SSS.

The CBT finances investment and operational costs of TIC-ESTS. The CBT charges message fee to the system participants in order to recover investment and operational costs of TIC-ESTS.

1. Amount of paid-in capital and retained earnings?

Not applicable.

2. Guarantees, insurance coverage or other similar arrangements?

Not applicable.

3. Credit lines or letters of credit?

Not applicable.

4. Powers to assess participants or equity holders?

Not applicable.

G. Please describe whether the SSS or its operator is subject to authorisation, supervision or oversight by an external authority.

CBT is subject to authorisation, supervision and oversight by various external public authorities.

II. Rules and procedures of the SSS

A. Does the SSS maintain a complete list of the rules and procedures governing the rights and obligations of participants and the duties of the SSS?

Yes. Complete list of rules and procedures governing the rights and obligations of participants and duties of TIC-ESTS is described in the books namely “Operational Rule-book” and “Utilization Rule-book” that the participants commit to fully comply by signing the participation contract. There are also circulars that regulate the operational details, issued by the CBT.

1. How can participants obtain a copy of the rules and procedures?

Related documents are sent to participants when they apply for the participation in the system, any changes in the documents are announced and distributed immediately. They are also available in the CBT web site and CBT provides them to the related parties on request.

2. Does other documentation provided to participants (e.g. user guides) have the same status as the rules and procedures?

In addition to operational and utilization rule-books, participants are provided with several other documentation such as: functional and technical specifications of system components, training documents, user guides, acceptance test specifications etc. These documents can also be accessed in the CBT web site.

3. Describe the process for changing rules and procedures, including any need for regulatory approval.

(a) What authority is required, and how does this differ depending on the type of change involved?

Change in the rules and procedures require a collaborative work by the CBT, Turkey’s Banks Association (TBA) and participants.

There is another committee in TBA including the participants’ RTGS and securities related staff where daily operations are discussed in detail and proper practices that are not covered in the Rule Books are discussed and reported back to the CBT’s decision committees to revise the current rules and re-publish the Rule Books, if required.

The final decision for all kind of changes in the rules and procedures are taken by the CBT in coordination with the TBA committee as written in the rule-book.

(b) How are participants notified of changes in rules and procedures?

Any changes in the rules and procedures are announced and distributed immediately to the participants.

(c) Is there a procedure for participants or others to comment on proposed rule changes?

Participants have contributions to the rules and procedures individually or through TBA before they are finalised.

B. Are the rules and procedures binding on the SSS as well as its participants? Under what conditions and on whose authority can written rules and procedures be waived or suspended by the SSS?

Yes, The rules are binding on TIC-ESTS and CBT as well as participants. The rules and procedures are not waived or suspended.

III. Relationships with participants

A. Please describe the types of membership offered by the SSS.

1. How do the types differ?

There is only one type of membership. All participants have equal rights. Only the banks, that are members of the TIC-RTGS system are eligible for participation.

2. Within each membership category, are all participants subject to the same rules and procedures? Please describe important exceptions, including both differences in rules across participants and the rationale for these differences.

Since there is a unique type of membership, all members are subject to same rules and procedures.

B. Can participants establish accounts for their customers' assets that are segregated from their own asset accounts at the SSS?

Yes, participants establish accounts for their customers' assets. According to the rule-book third parties do not have any right on the accounts and securities of a participant in the SSS. The CBT does not reflect on their records any interest of participant's customers in book-entry securities held in TIC-ESTS for such participant. A participant is responsible for maintaining accurate and current records with regard to book-entry securities that it holds for its customers in accordance with applicable law.

On the other hand, the participants have obligation to hold assets that are subject of repo operation with their customers in a separate sub-account (compulsory segregation). The CBT controls these assets by comparing TIC-ESTS holdings against data that is obtained from the participants through the CBT's on-line information gathering system.

Participant also may hold book-entry securities for the account of its customers that are not subject to repo operation in a separate TIC-ESTS sub-account that is defined for this purpose (optional segregation).

1. If so, is this accomplished through a single omnibus customer account or through a multiplicity of accounts and/or sub-accounts?

Each participant has set of sub-accounts in the TIC-ESTS system. Some of these accounts are used to group pledged securities as collateral by CBT (an approval is required during the transfer to and from these accounts), while the others are non-collateral.

Each participant has a separate sub-account to hold assets that are subject of repo operation with customers only.

2. Is the segregation optional or compulsory?

It is compulsory for securities of a participant that are subject of repo operation with their customers, while it is optional for customer securities that are not subject to repo operation.

3. Does the fact that a sub-account at the SSS bears the name of a third party give any rights to that third party as a participant under the rules of the system?

No. According to the rule-book third parties do not have any right on the accounts and securities of a participant in the system. The name of the account (for, example “Repo Collateral Account”) does not give rise to any third-party rights.

C. Please describe participant requirements for each type of membership.

1. Are participants required to be domiciled or resident in a particular jurisdiction?

Participants should be resident in Turkey and should also be the members of TIC-RTGS system.

2. Are participants required to be subject to a supervisory regime? If so, please describe.

Participants of the system are all banks that are subject to supervision by the CBT and the Banking Supervisory Board (BSB).

3. Are participants required to hold an equity stake in the SSS?

No.

4. Are there financial, economic, personal or other requirements (e.g. minimum capital requirements, "fit and proper" tests)? If so, please describe.

The participants should also be the members of TIC-RTGS system.

D. Does the SSS engage in oversight of its participants to ensure that their actions are in accordance with its rules and procedures? If so, please describe.

Yes. In addition to its financial supervisory role over the banks, the CBT also has an oversight role for the compliance of the participants on the rules and procedures.

E. Under what conditions can participants terminate their membership in the SSS? Does this mark the end of all liabilities of the participant? If not, please describe what liabilities could remain.

Since the participants of TIC-ESTS are also the members of TIC-RTGS, they terminate the TIC-RTGS and TIC-ESTS membership at the same time.

The rule-book states that, a participant should inform the CBT about the termination of its membership 3 months in advance. However, they remain liable for any transactions received prior to termination.

F. Under what conditions can the SSS terminate a participant's membership in the SSS?

The CBT has the authority to warn or take a participant, who does not fulfil their obligations, out of the system temporarily or permanently, as stated in the related article of the operational rule-book.

G. Please describe the scope of the SSS's liability to participants, including the standard of liability (negligence, gross negligence, wilful misconduct, strict liability or other), the force majeure standard, and any limitation to the scope of liability of the SSS (e.g. indirect or consequential damages). Where are these liabilities and their limitations set out (e.g. in statute or contract)?

The scope of the CBT's liability is defined in the operational rule-book. As stated in the rule-book, CBT is obliged to keep participants' security sub-accounts and book-entry security information pertaining to these sub-accounts in the system, to move the securities into the system by taking a delivery on request of participants, and take the immobilised securities out of the system and deliver to the participants on request. The CBT is not responsible for the consequences of fund/security transfers performed by other participants. The CBT cannot be held responsible for if TIC-RTGS / ESTS Operation Center cannot perform its duties under unexpected conditions or for reasons of force majeure. The CBT shows the utmost care to have the system run smoothly and settle all requests.

IV. Relationships with other SSSs and commercial intermediaries

A. Does the SSS maintain linkages (including sub-custodian or cash correspondent relationships) or other relationships with other SSSs?

Takasbank is the clearing and custody bank of ISE. It has separate SSS in which its participants access to their accounts using separate environment. Takasbank is also a member of TIC-RTGS in which it has a settlement account and TIC-ESTS in which it has security sub-accounts. Securities transferred to Takasbank's account in TIC-ESTS are indirectly transferred to Takasbank SSS.

The participants of the Takasbank SSS are banks (which are also participants of TIC-ESTS) and brokers (which are not allowed to participate in TIC-ESTS).

Takasbank settles trades performed on ISE with multilateral netting using the securities and sub-accounts on TIC-ESTS and funds on TIC-RTGS. As a result of netting of securities transactions in the ISE, Takasbank reports their obligations to the banks. Banks cover their security obligations by transferring securities from their sub-accounts to Takasbank's sub-account in TIC-ESTS, and send funds to Takasbank's account in TIC-RTGS in order to meet their funds obligations. The interaction between the TIC-ESTS and Takasbank SSS is given in Figure-1 below.

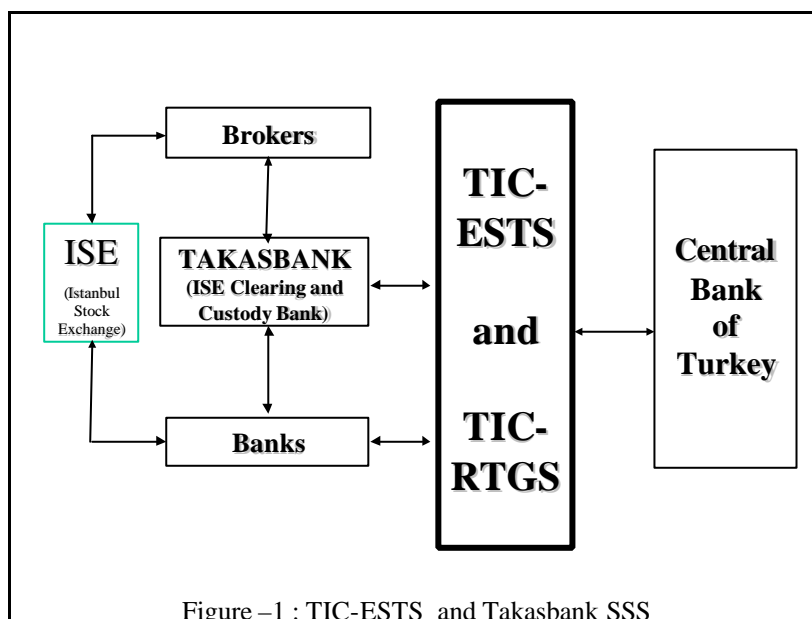

Figure -1 : TIC-ESTS and Takasbank SSS

1. Please identify each of the other SSSs used and the type of securities transferred via the linkages.

(a) What is the name of the other SSS? Where is it located?

Takasbank SSS, located in Istanbul-Turkey.

(b) What securities are eligible for transfer via the linkage to the other SSS?

Takasbank has security sub-accounts in TIC-ESTS. Securities transferred to Takasbank's sub-accounts in TIC-ESTS are indirectly transferred to Takasbank SSS. All the securities within the scope of TIC-ESTS (which are Government bonds and treasury bills) are eligible for transfer.

(c) Are transfers of securities made via the linkage to the other SSS limited to only those that are free of payment or are transfers against payment also made via the linkage to the other SSS? If against payment, please describe the timing of the transfers and the corresponding payments.

TIC-ESTS and Takasbank SSS use funds on TIC-RTGS to settle money leg of the DVP transactions. The transfers between the SSSs may be both against payment or free of payment. For DVP transfers funds and securities are exchanged simultaneously (simultaneous DVP in model 1).

(d) Does the other SSS provide custody services to the SSS and, if so, who bears any credit or custody risks?

No. Takasbank SSS does not provide custody services to TIC-ESTS. On the other hand, the securities of the Takasbank SSS are actually those that are in Takasbank's sub-accounts in the TIC-ESTS (dematerialised or immobilised in CBT branches), so that TIC-ESTS provides custody service to Takasbank.

B. Does the SSS use securities custodians (other than the other SSSs addressed in the previous question) and/or commercial cash correspondents? Please identify the custodians or cash correspondents used and the duties that each performs.

No.

C. Please describe the standards used in approving or reviewing relationships with other SSSs, custodians or cash correspondents, including any financial or operational requirements or the presence of insurance or public supervision.

Relationship between TIC-ESTS and Takasbank SSS is not a protocol based. Takasbank is a member in TIC-ESTS and any transfer in TIC-ESTS is a transfer to Takasbank SSS, similarly any transfer from Takasbank to another TIC-ESTS participant is a transfer from Takasbank SSS.

Under the CBT Law, CBT is also responsible oversight of the payment and settlement systems. In this context the CBT has oversight role over all the payment and settlement systems including Takasbank SSS.

D. Does the SSS advance funds or securities to or on behalf of other intermediaries such as issuing or paying agents? If so, please identify the circumstances in which such exposure could arise.

No.

E. Please describe measures in place to protect the SSS and its members against the failure of other SSSs or commercial intermediaries to meet obligations to the SSS, including risk controls, collateral or alternative sources of funds and securities.

The CBT does not give security overdrafts in the TIC-ESTS system, so that participants, including Takasbank, are only permitted to do transfers in case, only if sufficient securities are in their accounts. In addition, DVP in model 1, which is applied in TIC-ESTS provides an extra protection for the participants.

V. Securities transfers, funds transfers and linkages between transfers

A. Please discuss whether and how settlement instructions are matched between participants prior to processing by the SSS.

TIC-ESTS does not provide a trade matching service for its participants.

Matching, as a part of the settlement, is required only for DVP settlement requests. During a DVP transaction, seller enters its sell request first, than the buyer should enter its buy request(s). The sell and buy requests should match (security id, correspondent participant, amount, security quantity). A typical DVP flow in the TIC-ESTS is given in the Figure-2 below.

For other type of transactions, such as free of payment transfers, matching is not required.

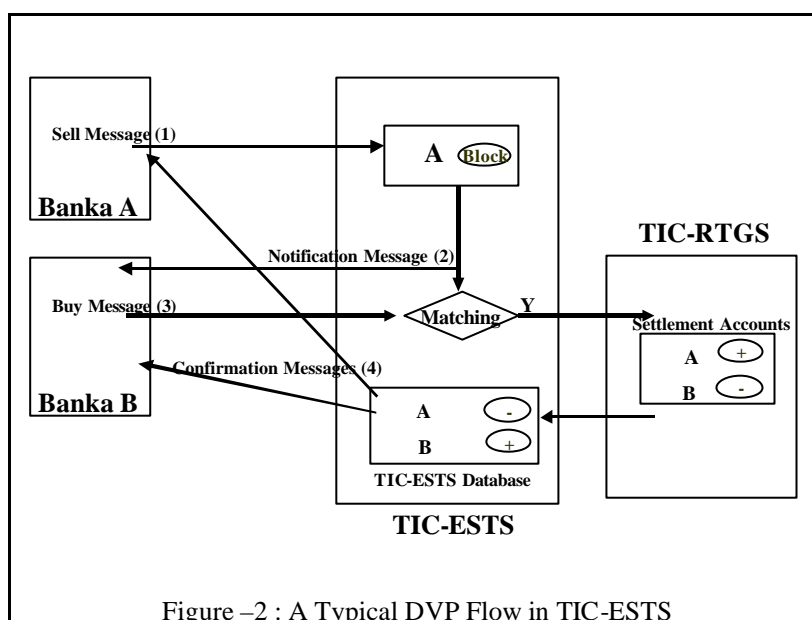

1. Is matching required for all transactions without exception?

Matching is required only for DVP transactions. See Figure-2 above for details.

2. What procedure is used when instructions do not match?

Unmatched or unsettled DVP sell instructions are cancelled during end of day operations.

3. Are matched settlement instructions binding on participants?

(a) If so, please describe the consequences of failure by participants to meet obligations (e.g. forced settlement, penalties, short positions).

Since real-time DVP is applied matched settlement instructions are settled immediately if funds are available in TIC-RTGS. On the other hand, it is possible to cancel matched but not settled instructions because of insufficient funds by parties (if they are not cancelled by the parties, matched but not settled instructions are cancelled by the system automatically during the end of day operations). In these situations there is no penalty or forced settlement in the SSS.

(b) Please describe whether this is a feature of the SSS's rules and procedures or of national law or regulations.

This is the feature of TIC-ESTS rules and procedures.

(c) Please provide a time line indicating the points at which matched instructions become binding, as well as any pre-matching process that takes place.

Not applicable.

B. Are securities transferred within the SSS registered?

No. Book-entry accounts with the CBT are limited to direct TIC-ESTS participants. All other owners of book-entry securities must maintain their securities either directly or indirectly with one of these participants. The CBT does not know the identity of any customers other than TIC-ESTS participant.

1. Who is the registrar?

Not applicable.

2. Is it normal practice to register the securities in the name of the SSS (or its nominee) or in the name of the beneficial owner? Are there instances in which securities housed within the SSS are registered to neither the SSS (or its nominee) nor the beneficial owner?

Not applicable.

3. If the SSS offers custodial services, will it hold securities registered in the name of the beneficial owner?

Not applicable.

4. Under what circumstances does the SSS initiate registration of securities in the buyer's name?

Not applicable.

5. How long does the registration process typically take? Are participants notified when registration is complete?

Not applicable.

6. Can securities be transferred within the SSS before registration in the buyer's name is complete? If so, do the rules and procedures of the SSS provide for an unwind or reversal of such transfers in case of bankruptcy or other events which result in the buyer's name not being entered on the register?

Not applicable.

C. Please describe how securities transfers are processed within the SSS.

Transfers are initiated by the deliverer of the securities and will be automatically rejected unless the deliverer has sufficient securities. Transfers may be free or against payment. While free transfers do not require approval from the recipient, DVP transfers need the matching of sell and corresponding buy instructions (please refer to section V-A and Figure-2). The CBT may also have a direct debit facility between participants' sub-accounts.

1. Please indicate whether the transfers are processed as debits and credits to members' accounts or via some other method.

Securities transfers are realized by debiting and crediting the member's security sub-accounts.

2. On a continuous (real-time) basis, or in one or more batches?

Securities transfers are realized on continuous real time basis.

3. If continuous, during what hours does the processing occur? If in batches, at what time or times is the processing initiated and completed?

Transfers are settled in real-time during business working hours of TIC-ESTS.

Settlement in TIC-ESTS is closed at 17:30 every night. But the CBT has a right to extent the working hours of the system.

It is opened at 8:30 on the first working day after a holiday, and approximately 3 hours later than the closing of the system on other working days.

4. Do securities settlements occur daily? Please identify securities for which settlement occurs only on specific days of the week or month.

Securities settlement occurs on every business day. There is no specific day determined for any security.

D. Please describe whether final funds transfers in conjunction with the SSS are made as debits and credits to balances held at the SSS, at one or more commercial banks, at the central bank, or via some other method.

TIC-ESTS has integrated with TIC-RTGS (real-time gross settlement payment system of the CBT). The connection between TIC-ESTS and TIC-RTGS allows simultaneous DVP in model 1.

1. Does the SSS maintain cash accounts for its participants? Are these accounts equivalent to deposit accounts at a commercial or central bank or do they serve only as "cash memorandum" accounts?

TIC-ESTS does not contain cash accounts. In settlement of the money leg of DVP transactions settlement accounts in TIC-RTGS is used by real-time connection between TIC-ESTS and TIC-RTGS, so that, simultaneous DVP in model 1 is achieved.

2. On what entity (SSS or other) does the participant bear cash deposit risk?

Not applicable.

3. Under what circumstances does the SSS provide credit extensions or advances of funds to its participants and thereby expose itself to credit risk?

The CBT does not advance funds to any institution or does not give any security overdrafts in the TIC-ESTS system. However, it gives light overdraft to TIC-RTGS participants against full collateral.

4. How long can such credit extensions last? How long do they typically last?

Funds overdrafts should be closed during the same business day by the time determined by CBT.

E. Is the SSS a DVP system? If so, please describe the DVP model used according to the models outlined in the DVP Report (see the Introduction). Please also provide a diagram indicating the timing of events in the processing of securities and funds transfers in the SSS. Where the SSS

provides more than one alternative for settlement processing, please provide a response for each alternative and indicate the relative importance of each alternative.

TIC-ESTS is a real time DVP (Model1) system. This is, TIC-ESTS settles transfer instructions for both securities and funds in trade-by-trade (gross) basis, with final (unconditional) transfers of securities from seller to buyer (delivery) occurring at the time as final transfer of funds from the buyer to the seller.

1. Are funds transfers and securities transfers processed within the same system or in different systems? If different, how are they linked?

Funds are settled in TIC-RTGS while securities transfer is performed in TIC-ESTS. They are linked to each other by real time application level connection.

(a) Please describe whether each securities transfer is linked to a specific funds transfer on a trade-by-trade basis or on a net basis or via some other method.

Each securities transfer is linked to specific funds transfer on a trade-by-trade basis.

(b) Does the SSS "split" large transactions into multiple transactions or require participants to do so?

TIC-ESTS does not change transaction entered by its participants. But it allows participants to settle DVP transactions in parts (partial DVP operation). If seller and buyer agree on the partial settlement, buyer can send payment in parts, and only a part of the securities are delivered in TIC-ESTS with respect to the payment. Figure-3 below presents a typical partial DVP operation in TIC-ESTS.

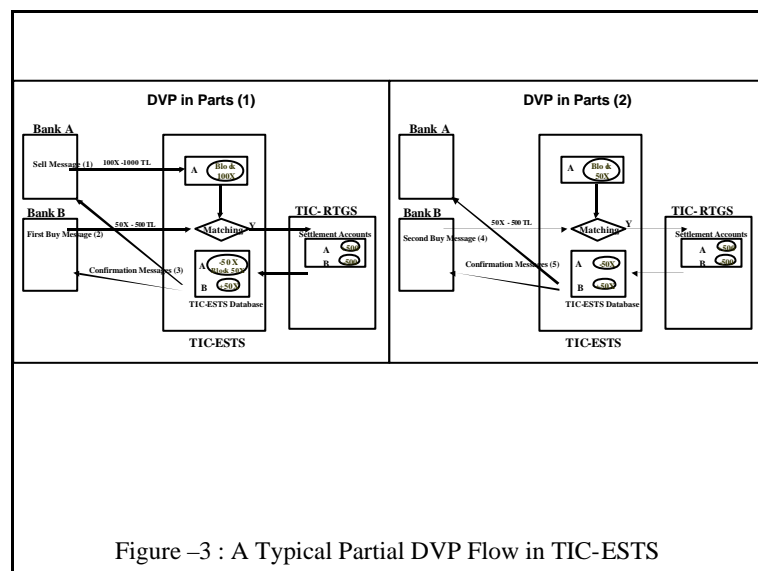

2. When do securities transfers and funds transfers become final?

(a) At what time do securities transfers become final? After what event or events?

All debits and credits in connection with a securities transfer become final at the time the debits and credits are posted to both sender's and receiver's securities accounts, in the case of transfer against payment, their corresponding funds accounts in TIC-RTGS. Notice of the transfer is conclusive evidence that the debit(s) and credit(s) were made.

(b) At what time do funds transfers become final? After what event or events? Does this timing allow for same-day retransfer of funds received in exchange for securities?

Funds transfers associated with securities transfers become final in a manner described above and may be retransferred on the day of receipt.

(c) If final delivery of securities precedes the final transfer of funds, can participants dispose freely of such securities prior to funds finality? If so, what actions will be taken if funds are not received?

Not applicable.

(d) If final delivery of funds precedes the final transfer of securities, can participants dispose freely of such funds prior to securities finality? If so, what actions will be taken if securities are not received?

Not applicable.

(e) Does the timing of finality differ depending on the type of security transferred or the currency in which payment is to be made? Please describe.

No.

3. Please discuss whether participants are notified of securities or funds transfers while they are still provisional, only when they are final, or both.

Securities and funds transfers in TIC-RTGS and TIC-RTGS are not provisional. Participants receive notification of funds and securities transfers as they are processed.

F. Does the SSS itself "guarantee" funds or securities transfers?

No.

1. Under what circumstances and at what point are transfers guaranteed by the SSS?

Not applicable.

2. What actions does the guarantee obligate the SSS to take?

Not applicable.

3. Please indicate whether the guarantee is a feature of the SSS's rules and procedures or of national law or regulations.

Not applicable.

VI. Default procedures

A. Please discuss the events or circumstances that would constitute default of a participant under the rules and procedures of the SSS or that would lead the SSS to make use of exceptional settlement arrangements or unwind procedures.

In no case, the CBT unwind fund or security transfers.

1. Failure by a participant to meet a test of its solvency under the applicable laws of its jurisdiction?

A participant that has been closed because of insolvency would generally not be permitted to continue participating in TIC-ESTS.

2. Failure to make payments or deliveries of securities within the time specified?

Not applicable.

3. To the extent that the rules and procedures grant discretion in the determination of the use of default or other exceptional procedures, please discuss where the authority to exercise such discretion resides and the circumstances in which this authority would be used.

Not applicable.

B. What procedures are followed by the SSS once it has determined that a default event has occurred or that exceptional settlement arrangements are to be employed?

As a real-time gross settlement system, TIC-ESTS would not need to employ exceptional settlement agreements.

1. How and at what point are participants notified that this has occurred?

Not applicable.

2. Would the SSS be expected to continue to meet all its obligations to participants under these circumstances? Please discuss the resources in place to ensure that this would occur (e.g. collateral, participants' fund, insurance, loss-sharing arrangements, etc.).

Not applicable.

3. Please describe and provide a time line indicating the order in which these resources would be used as well as the timing of participant notifications and important deadlines (e.g. when the SSS's obligations to participants would be met, when participants would need to cover their loss-sharing obligations).

Not applicable.

4. Please describe all conditions under which provisional transfers of securities or funds could be unwound by the SSS.

Not applicable. Transfers of securities and funds on TIC-ESTS and TIC-RTGS are final.

(a) How and on what authority would a decision to unwind securities or funds transfers be made by the SSS?

Not applicable.

(b) When and how would participants be notified of a decision to unwind provisional securities or funds transfers?

Not applicable.

(c) How long would participants have to cover any debit positions in their own securities or funds accounts resulting from an unwind?

Not applicable.

(d) In the event of an unwind, would all transfers be unwound or would only a subset of transfers (e.g. only securities purchases or only those of a subset of participants) be unwound?

Not applicable.

(e) If only a subset of transfers, what procedure would be followed to determine which transfers and in what order?

Not applicable.

5. Can bankruptcy or insolvency be declared retrospectively in the SSS's jurisdiction (e.g. under a "zero-hour" rule), and could this cause provisional securities or funds transfers to be unwound?

No.

6. Please describe any circumstances in which transfers of securities or funds that were defined as final in response to question V.E.2 above would ever be unwound.

None.

C. Has a participant in the SSS ever been declared in default or become insolvent?

Participants have become insolvent but the CBT has never incurred a loss from the failure of a TIC-ESTS participant.

1. Have loss-sharing procedures been invoked?

Not applicable.

2. Please describe whether any of these defaults or insolvencies resulted in losses for the SSS or its participants and how they were absorbed.

No. See above.

VII. Securities overdrafts, securities lending and back-to-back transactions

A. Is it possible for debit positions (overdrafts) in securities accounts at the SSS to arise?

No. Participants cannot overdraw their securities accounts. TIC-ESTS will prevent the transfer of securities that are not positioned in a participant's securities account.

1. Under what conditions could such debit positions occur?

Not applicable.

(a) Do these conditions always result in debit positions in securities accounts rather than failed transactions? If not, please explain the basis for differential treatment by the SSS.

Not applicable.

(b) Are these situations covered explicitly by the rules and procedures of the SSS?

Not applicable.

2. How long can such debit positions last? How long do they typically last?

Not applicable.

3. How are debit positions in securities accounts prevented, rectified or managed?

TIC-ESTS prevents debit positions by rejecting transfers requests that would result in a debit position in the securities account.

4. What procedures would be followed by the SSS in case the debit cannot be rectified? (e.g. failure by a participant with a debit balance in a securities account or unavailability of the securities in the market)

Not applicable.

(a) Application of loss-sharing provisions allocating the loss to participants?

Not applicable.

(b) Absorption of the loss by the SSS?

Not applicable.

(c) Other? Please specify.

Not applicable.

B. Under what circumstances does the SSS provide for the lending of securities to ensure settlements?

TIC-ESTS does not offer any securities lending or borrowing programme, but it allows repo (repurchase agreements) and repo-return transactions between participants.

1. Is the process for lending securities automatic? If not, please describe the procedures used by the SSS to determine whether a securities loan will be made.

Not applicable.

2. At what point are participants notified that securities are being lent to them in order to complete their settlements?

Not applicable.

3. Which securities on deposit at the SSS are eligible for lending? Do participants have the option to make securities available for lending or is it mandatory?

Not applicable.

4. Are lent securities identified by the SSS with specific participants as lenders or only with a common pool of securities available for lending? Does the participant whose securities are lent become a principal to the transaction?

Not applicable.

C. How does the SSS settle back-to-back transactions?

Back-to-back transactions are settled by separate transfers messages. A participant involved in a back-to-back transaction first receives the securities from the other participant over TIC-ESTS and then delivers them to another participant over TIC-ESTS. Of course, a participant may deliver securities before receiving them if the participant already has sufficient securities in its sub-accounts.

1. Under what conditions are delivery instructions by participants receiving and redelivering securities on the same day under back-to-back transactions settled for same-day value?

All TIC-ESTS transfers are settled immediately for same-day value.

(a) Only if the participant has securities on deposit with the SSS that have been received pursuant to a final securities transfer?

Not applicable.

(b) If the participant has securities on deposit with the SSS that have been received pursuant to a provisional securities transfer?

Not applicable.

(c) Before securities have been received either provisionally or finally, but when a matched receipt instruction exists for the same or greater value? Is such a practice limited to markets where matching is binding?

Not applicable.

(d) Before securities have been received either provisionally or finally, but when a third party has promised to deliver to the SSS securities of the same or greater value? Must the provider of the guarantee have itself received the securities through a final transfer? Please describe how the SSS evaluates such promises, and whether they are addressed by the written rules and procedures of the SSS.

Not applicable.

(e) Other? Please specify.

Not applicable.

2. Please describe limits or controls in place with respect to any of the above arrangements for the settlement of back-to-back transactions, including limits on amounts involved or related to the liquidity of the underlying securities.

The limits or controls that apply to back-to-back transactions are the same limits and controls that apply to all TIC-ESTS transactions.

3. Under what conditions are payment instructions by participants in the SSS under back-to-back transactions settled for same-day value? Can participants use the proceeds of an on-delivery of securities without the need for an extension of credit?

All fund transfers over TIC-RTGS are for same-day value. Participants can use the proceeds of an on-delivery of securities without need for an extension of credit.

VIII. Risk control measures

A. Please describe the roles and responsibilities of those areas of the SSS responsible for risk management and control.

The CBT is the entity that is fully responsible for the risk management. The CBT perform this function through HITI committee (Please see I.E.3 for details).

Payment systems objectives are defined by The Board of the CBT and HITI Committee, then implementation details of defined policies are discussed on the working groups, finally the action plan is presented to the HITI committee for approval. The decisions of the HITI committee are reviewed by the Board, if they are directly related to the payment system objectives.

Working group consists of experts from the CBT departments that are presented in the HITI committee.

CBT provides the following risk management tasks:

1. As explained before, DVP method is applied in settlement,
2. Securities balances are reconciled daily with depository records from the CBT branches,
3. Depository records of the immobilised securities are based on serial numbers and detected by the system on each delivery and acceptance of stocks,
4. Members' access to the system is through private network that is owned and operated by the CBT. Highest level of securities features are applied on the network and applications, (encryption, closed user groups, session level log-in keys, passwords...)
5. Participants can monitor their current positions and transactions in TIC-ESTS and TIC-RTGS on-line.

1. Please describe the process for the internal review of risk management policies and procedures.

Working groups meet when there is a request from any of the departments represented in the HITI committee. Operational and technical decisions are taken by the CBT working groups.

If a major change in the operational rule-book or related circular which is directly related with payment system strategies, then working group calls HITI committee for meeting. Then HITI committee decides on the issue and presents it to the Board in case it requires a change in the operational-rules or in the payment system objectives.

In addition to the extraordinary meetings, HITI committee meets at least once a year to evaluate the operations of the system and present results to board of the CBT.

2. Is there a risk management policy that addresses the review and approval of new products and services offered by the SSS? At what level of the organisation is risk management approval given for a new product or service?

All new applications and services that are offered by or that may affect the operations of TIC-ESTS are first discussed in the working groups, then, if necessary, it is presented to HITI committee and then to the Board. During this process views from all the related departments are evaluated and all the related circulars are investigated. This process prevents the risk incurred from the new service. All new applications and services offered by TIC-ESTS are also discussed with the participants in the appropriate platforms, and all the new services are tested in the test environment with the inclusion of the participants.

3. Does the SSS have a risk management function with clear independence from and authority over operational or marketing functions?

All the CBT departments, that are given in section I.E.3.a involve in the risk management function.

4. Does the Board of Directors review risk management policies and procedures? Does the Board have a risk management or audit committee?

The Board of the CBT review the TIC-ESTS risk management policies by means of HITI committee. HITI committee makes policy level decisions and some of the issues where the Board decision required are taken to the Board.

B. Please describe any internal or external audits or supervisory/regulatory examinations that are performed with respect to the SSS. For each such audit or examination, please address the following questions.

The CBT is subject to independent external auditing, under the CBT Law. Since, TIC-ESTS is a part of the CBT organisation, it is possible to have independent external auditing for TIC-ESTS. External independent auditors include the accounts of TIC-ESTS in the contents of their periodical audits. The audits for TIC-ESTS may also be carried out within the CBT internally.

In addition, as stated in the rule-book, the CBT is authorised to audit security and operational practices of the participants with regard to TIC-ESTS.

C. Please discuss whether the SSS has the capacity to value (i.e. mark to market) the securities that it holds.

All the securities, which are eligible for TIC-ESTS, have official values that are announced daily by the CBT based on prices appeared in the market. These prices are reflected to the TIC-ESTS and automatically distributed to the participants through the system. Participants and the CBT departments using TIC-ESTS facilities see the marked-to-market values of their holdings in their queries.

1. Please describe how these valuations are used by risk control systems at the SSS.

Participants' securities that are in the collateral accounts can be used as a collateral in the CBT markets (such as interbank money market or foreign exchange market). Also some of the securities in the TIC-ESTS are counted in the Liquidity Requirement calculations.

Official values of security holdings are used in the calculation of collateral and Liquidity Requirements values in the CBT.

2. How frequently are securities revalued?

Securities are revaluated on a daily basis.

3. What are the sources for security valuations?

Securities are revaluated on a daily basis by using linear pricing models.

(a) What outside price or data sources are used?

Secondary market prices and maturities of the securities are used in the revaluation process.

(b) If pricing models are used, please describe how the models are chosen and how the model inputs are obtained.

A yield curve is established by using prices of the securities that trade in the secondary market. A model that reflects this yield curve the best is used in calculating the prices of all securities.

D. Please discuss whether the SSS has a lien on the securities held in or transferred through it.

TIC-ESTS, itself, does not have a lien on the securities held in or transferred through it. However, as described in the DVP transaction flow, the securities that are subject to DVP transactions are blocked in the system until the DVP transaction settles or cancelled.

1. Does the lien apply only to the securities owned by the participants themselves or does it extend to the securities beneficially owned by customers of participants?

Not applicable.

2. Under what circumstances and in what manner would such a lien allow the SSS to use the securities?

Not applicable.

E. Please discuss the circumstances in which the SSS requires collateral to limit or mitigate risks.

TIC-ESTS participants are not required to supply collateral to the TIC-ESTS in order to use the system. TIC-ESTS does not require collateral to mitigate risks because, (1) TIC-ESTS is not a netting system, the system process each settlement order individually in real time, (2) No security overdraft is given to participants in the TIC-ESTS system, so that participants are only permitted to do transfers in case, only if sufficient securities are in their accounts. In addition, DVP in model 1, which is applied in TIC-ESTS provides an extra protection for the participants.

1. Does the SSS manage its own collateral system?

Not applicable.

2. Does the SSS share a collateral system with another SSS or payment system?

No.

3. Can collateral at the SSS be posted and returned on the same day?

Not applicable.

4. What types of transaction at the SSS involve the use of collateral?

Not applicable.

5. What are the policies with regard to the type of collateral used or haircuts required?

Not applicable.

6. How are collateral valuation methodologies developed and reviewed?

Not applicable.

7. To what extent are collateral policies described in the written rules and procedures of the SSS?

Not applicable.

F. Please describe the SSS's use of limits on exposures to monitor or control risks.

TIC-ESTS is security settlement and transfer system that performs DVP in model 1, and does not allow security overdrafts. The participants can only enter transfer orders if they have enough securities in the system, otherwise the transfer orders are rejected by the system automatically. So there are no limits on exposures to monitor and control risk in TIC-ESTS.

1. Please explain the types of limit used and the exposures to which they apply.

Not applicable.

2. Do the limits apply to all participants and/or to other SSSs with which the SSS is linked? What are the exceptions to the limits?

Not applicable.

3. Do limits apply to participants individually or in the aggregate or both?

Not applicable.

4. Do limits apply to implicit as well as explicit extensions of credit or securities (e.g. when on-deliveries of securities are permitted pursuant to provisional but not final delivery of securities)?

Not applicable.

5. Does the SSS automatically reject transactions that exceed limits or is compliance determined ex post?

Not applicable.

6. How are limit policies developed and reviewed?

Not applicable.

7. To what extent are limit policies described in the written rules and procedures of the SSS? Where does additional authority to set or amend limit policies reside?

Not applicable.

G. Please describe other controls to mitigate or reduce risks at the SSS.

1. Does the SSS or its participants have the capacity to monitor participants' accounts continuously during processing?

Participants are able to monitor their accounts in real time. The CBT is able to monitor all the accounts in the system.

2. Is there a special risk control regime that the SSS would apply to a participant known to be experiencing financial difficulties?

Such a regime does not exist.

3. Does the SSS maintain or administer loss-sharing arrangements other than those applicable to events of default and addressed in Section VI above? Are these loss-sharing pools pre-funded by participants?

No.

IX. Operational risks

A. Please provide assessments of the operational reliability of the computer and other systems used by the SSS, including any criteria that the SSS uses internally for this purpose.

1. What is the percentage uptime of the systems used by the SSS?

In May 2000, the effective availability of the whole system is found 99.91% as a result of the assessment study, Business Critical Availability Review Service.

Since then new improvements to the technical infrastructure is done which will increase the availability of the overall system to 99.99%.

TIC-ESTS is in the production since the 30 October 2000, the up time was 99.99 % between the cut-over date and the 22 June 2001 (the time that the this document is released).

(a) Whole system overall?

See above.

(b) Broken down by major components? (e.g. communications network, central processing facility)

In 2000, uptime for the central processing components was 99.99%, network was 100%, participant side interfaces was 99.99%.

(c) During critical processing periods?

In 2000, uptime during critical hours was 100%.

2. Has the SSS experienced major operational problems during the past two years?

No.

(a) Have settlements been delayed, been disrupted or otherwise failed because of operational problems during this period?

No.

(b) Please describe the nature of any such problems.

Not applicable.

B. Please describe contingency or disaster recovery planning at the SSS.

Several levels of fault tolerance exist in the settlement system of the CBT (that includes TIC-ESTS and TIC-RTGS). The general architecture of CBT's Settlement System (TIC) is given in the Figure-5 below.

Firstly, the central components of the system (including TIC-ESTS centre) have no single point of failures. All network devices has backups, central hardware use clustering technology – in case of failure in one of the machines the other will take over the operations.

Secondly, the settlement system has a hot standby disaster centre that will take over the operations within one hour in case of permanent failure in the primary site. Disaster centre is placed on a geographically separate place, and all the settlement information is backed up to the disaster centre in real time using high speed fiber optic lines.

The private network (TIC-NET) and participant systems (Relay Computers – RC) have also backups that can be used in case of failure.

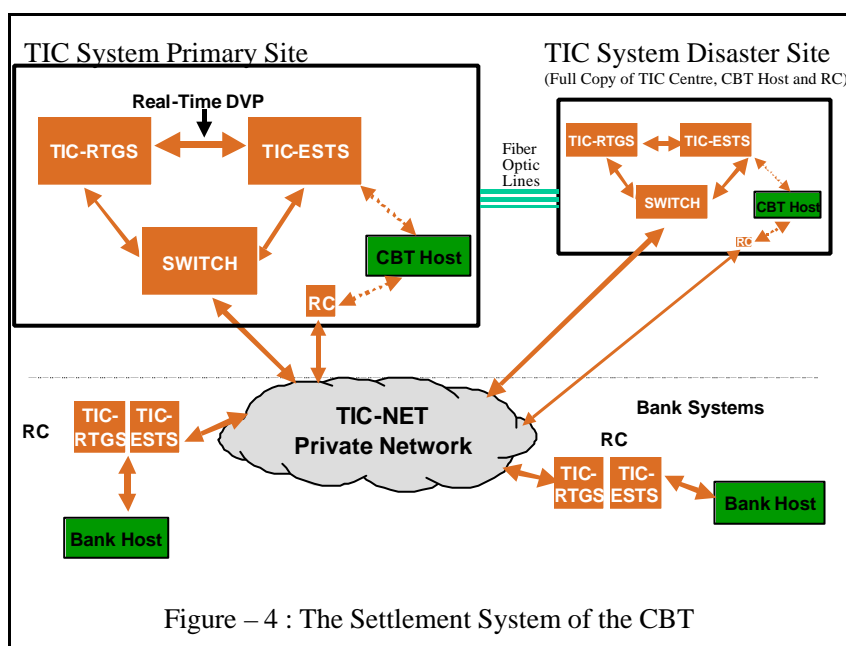

1. Does the SSS have a formal plan for business continuity in place?

Yes.

2. Is this plan available for review by participants?

Yes.

3. How often is this plan tested? Does this involve participants in the SSS?

The CBT maintains testing with its participants twice a year.

4. What are the major elements of the business continuity plan?

When there is a technical problem in the primary centre, depending on the nature of the problem, facilities in the primary centre is used to continue the operations of the system. This may include the starting the system on a local cluster, or replacing the failed part with the new one that is stored in the CBT premises.

If there is a total site failure (for example because of a natural disaster) the disaster site systems will be take over the operations within one hour without any message loss or duplication. This switch-over does not require any change in the participants' interfaces.

Failures in the participant systems are addressed by the CBT helpdesk whose main activity is to log and solve the participants' technical and operational problems related to TIC-ESTS and TIC-RTGS.

5. How long would it take the SSS to resume operations if primary systems become unusable?

Less than 1 hour.

C. What are the key features of the internal controls covering operations and security at the SSS (e.g. change controls or those covering remote access)?

TIC-ESTS and TIC-RTGS technical and operational departments are located in access restricted areas in the CBT headquarter with constant surveillance. User passwords are changed on specified intervals.

1. Please describe controls or security procedures in place to ensure that the SSS acts only on authentic settlement instructions from valid participants.

All the messages are encrypted between the participant and central systems. There are also other authentication and security mechanisms:

- (i) The CBT has its own closed network that is owned and operated by the CBT with regard to settlement systems. Each participant is given a specific network address by the CBT and this address is used in the application level controls.
- (ii) Each participant has a separate session level log-in keys that are controlled during the session initialisation by the participants.

2. Are internal operational and security controls included in the internal and/or external audits of the SSS?

Yes.

3. Are internal operational and security controls covered by regulatory requirements applicable to the SSS?

No.

D. Does the SSS impose minimum operational or performance standards on third parties (e.g. communications providers)?

Yes. The CBT has service and maintenance contracts with the third parties (firms that provide hardware or software support and maintenance). Based on these contracts, the CBT has performance and operational requirements on these firms.

1. How does the SSS ensure that such standards are met on a continuing basis and what sanctions are available to the SSS if they are not?

The CBT's participant helpdesk logs every call to third parties on close the call when they are solved. The operational and performance requirements that are given in the contracts are followed and controlled by the CBT's payment systems staff continuously based on the service calls.

2. How would the SSS allocate losses incurred due to operational problems caused by third parties?

The losses incurred due to operational or technical problems caused by third parties are allocated based on the liabilities that are defined in the service or maintenance contracts.